



## EV BATTERY CHARGING USING PIEZOELECTRIC ROADS

J. Vignesh\*, M. Vignesh\*\*, M. Thulasiraman\*\* & M. Vijay\*\*

\* Assistant Professor, Department of Electrical and Electronics Engineering, Dhanalakshmi Srinivasan Engineering College (Autonomous), Perambalur, Tamil Nadu, India

\*\* UG Student, Department of Electrical and Electronics Engineering, Dhanalakshmi Srinivasan Engineering College (Autonomous), Perambalur, Tamil Nadu, India

**Cite This Article:** J. Vignesh, M. Vignesh, M. Thulasiraman & M. Vijay, "EV Battery Charging Using Piezoelectric Roads", International Journal of Current Research and Modern Education, Volume 11, Issue 1, January - June, Page Number 97-100, 2026.

**Copy Right:** © Crystal Pen Publication, 2026 (All Rights Reserved). This is an Open Access Article distributed under the Creative Commons Attribution License, which permits unrestricted use, distribution, and reproduction in any medium, provided the original work is properly cited.

**Type of Review:** Peer Reviewed as per |C|O|P|E| Guidance.

**Disclaimer:** The scholarly papers reviewed and published by Crystal Pen Publication, India, reflect the views and opinions of their respective authors and do not necessarily represent the views or opinions of Crystal Pen Publication. The publisher disclaims any responsibility for any harm, loss, or damage resulting from the use of the published content by any party.

**DOI:** <https://doi.org/10.5281/zenodo.19861115>

### Abstract:

The increasing adoption of electric vehicles (EVs) has created a significant demand for efficient and sustainable charging solutions. Conventional charging systems largely depend on grid electricity, which is often generated from non-renewable sources, thereby reducing the environmental benefits of EVs. This paper proposes an innovative approach to EV battery charging using piezoelectric roads, where mechanical energy generated from moving vehicles is converted into electrical energy through embedded piezoelectric sensors. The harvested energy is conditioned, stored, and utilized for charging EV batteries using an intelligent microcontroller-based system. The system incorporates energy storage units, voltage and temperature monitoring, and real-time display mechanisms to ensure efficient and safe operation. This approach not only reduces dependency on conventional power grids but also transforms road infrastructure into renewable energy sources. The proposed system demonstrates a sustainable, scalable, and eco-friendly solution for future smart city transportation systems.

### 1. Introduction:

The global transition toward electric mobility has intensified the need for sustainable energy solutions to support electric vehicle charging infrastructure. Although EVs significantly reduce greenhouse gas emissions and reliance on fossil fuels, their charging systems still depend heavily on conventional electrical grids. These grids often rely on non-renewable energy sources such as coal and natural gas, which undermines the environmental benefits of electric transportation. Therefore, there is a growing need to explore alternative energy sources that are renewable, efficient, and capable of supporting large-scale EV adoption.

Piezoelectric energy harvesting has emerged as a promising solution in this context. Piezoelectric materials have the ability to convert mechanical stress into electrical energy. By embedding these materials beneath road surfaces, it becomes possible to capture the mechanical energy generated by moving vehicles and convert it into usable electrical power. This concept transforms conventional roadways into active energy-generating systems.

The integration of piezoelectric roads with EV charging systems creates a self-sustaining energy cycle. Vehicles contribute to energy generation through their movement, and the harvested energy is stored and reused for charging purposes. This approach not only enhances energy efficiency but also supports the development of smart and sustainable urban infrastructure.

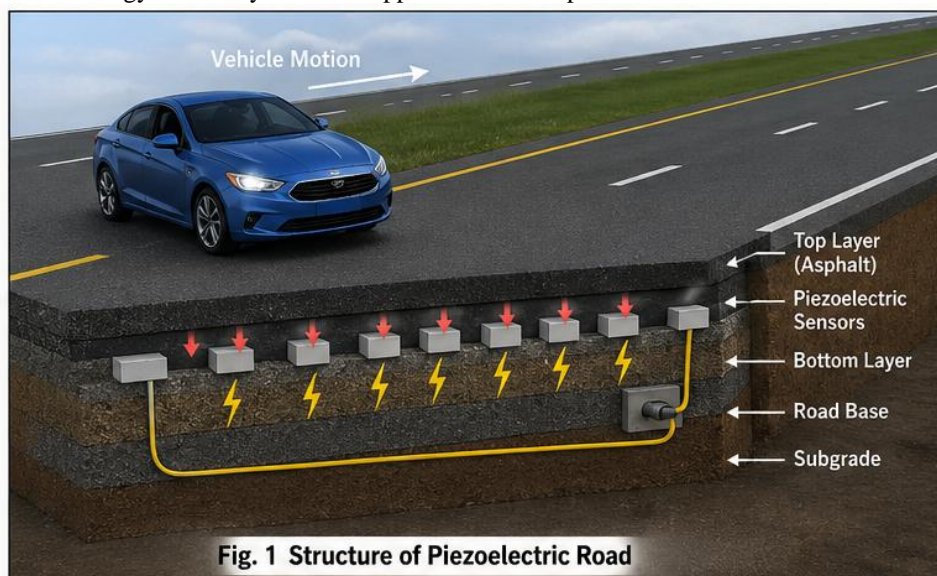

**Fig. 1 Structure of Piezoelectric Road**

### 2. Literature Survey:

Recent research has focused extensively on improving EV charging technologies and energy storage systems. Studies on second-use battery systems highlight the potential of repurposed EV batteries in supporting charging infrastructure and reducing grid dependency. These systems act as buffer storage units that help stabilize energy supply and manage peak loads effectively. Other research has examined the characteristics of fast charging in lithium-ion batteries, emphasizing the trade-off between

charging speed and battery health. High charging rates can lead to increased temperature and accelerated degradation, making intelligent control systems essential for safe operation.

Charging methods such as constant current constant voltage (CC-CV) and pulse charging have been analyzed for their efficiency and impact on battery life. The importance of charge equalization techniques has also been highlighted to maintain uniform charging across battery cells. Additionally, advancements in battery management systems (BMS), thermal management, and artificial intelligence-based charging algorithms have improved the efficiency and reliability of EV charging systems. IoT-based solutions have further enabled optimized load scheduling and real-time monitoring of charging operations. Despite these advancements, most existing systems still rely heavily on grid-based power, indicating a clear need for alternative energy harvesting solutions such as piezoelectric systems.

### 3. Existing System:

Conventional EV charging systems primarily depend on centralized electrical grids. These systems include slow chargers, fast chargers, and rapid DC chargers, all of which draw power directly from the grid. While these technologies have enabled the growth of electric vehicles, they present several limitations. One major issue is the dependence on non-renewable energy sources, which reduces the overall sustainability of EVs. Additionally, the increasing demand for charging infrastructure places significant stress on electrical grids, leading to potential overload and instability.

Existing systems also require high installation costs, including transformers, transmission lines, and safety equipment. Charging time remains another concern, as slow charging systems require extended durations, while fast chargers increase costs and may affect battery life. Furthermore, these systems do not utilize the mechanical energy generated by vehicle movement, resulting in wasted energy that could otherwise be harnessed. This highlights the need for innovative solutions that integrate energy harvesting with transportation infrastructure.

### 4. Proposed System:

The proposed system introduces a novel method of EV battery charging using piezoelectric roads. In this system, piezoelectric sensors are embedded beneath the road surface. When vehicles pass over these sensors, the mechanical pressure and vibrations generate electrical energy through the piezoelectric effect. The generated energy is initially in an unstable form and is passed through a rectification and voltage regulation circuit to produce stable DC output. This energy is then stored in a rechargeable battery, which serves as an energy buffer.

An Atmega328P microcontroller is used to manage the system. It monitors voltage levels, controls charging operations, and ensures safe energy distribution. Voltage and temperature sensors are integrated to prevent overcharging and overheating, thereby enhancing system reliability. The system also includes an LCD display that provides real-time information about energy generation, battery status, and system performance. This ensures transparency and ease of monitoring. Overall, the proposed system transforms roadways into energy-generating infrastructure, reducing reliance on conventional power sources and promoting sustainable transportation.

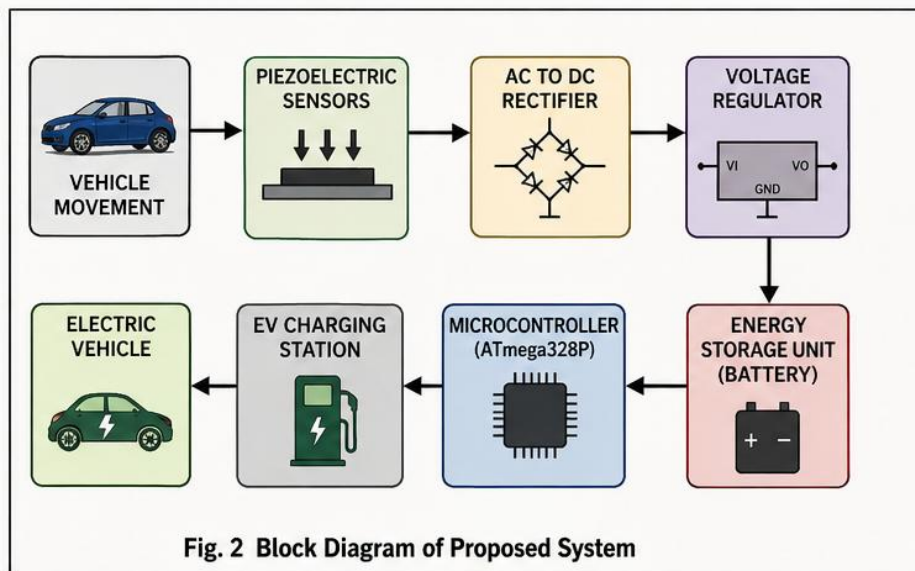
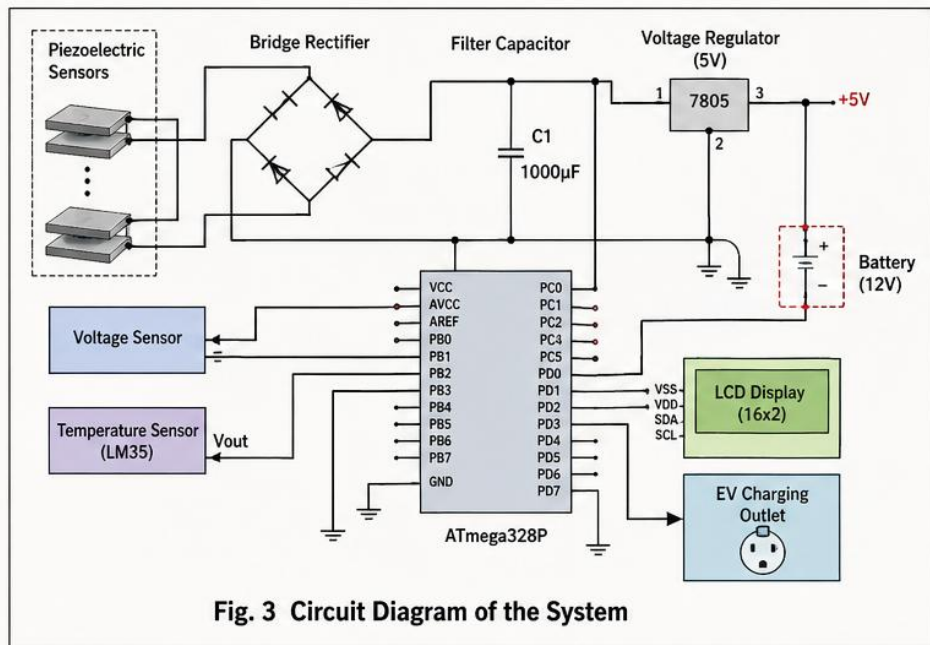

**Fig. 2 Block Diagram of Proposed System**

### 5. Methodology:

The operation of the proposed system begins with the initialization of all components, including sensors, microcontroller, storage unit, and display module. When a vehicle moves over the road, mechanical energy is captured by piezoelectric sensors and converted into electrical energy. This energy is then processed through a power conditioning circuit that stabilizes the output. The regulated energy is stored in a battery for later use. The microcontroller continuously monitors system parameters and controls the charging process based on real-time data.

Safety mechanisms are implemented using voltage and temperature sensors. If any abnormal condition is detected, the system automatically adjusts or shuts down to prevent damage. Finally, the stored energy is used to charge EV batteries, and system performance is displayed on the LCD. The process operates continuously, ensuring efficient energy harvesting and utilization.



### 6. Hardware Implementation:

The system consists of several key components, including piezoelectric sensors, lithium-ion batteries, voltage sensors, temperature sensors, and a microcontroller. Piezoelectric sensors act as the primary energy harvesting units. They convert mechanical stress into electrical signals. Lithium-ion batteries are used for energy storage due to their high energy density and long cycle life.

Voltage sensors monitor the electrical output, ensuring stable operation, while temperature sensors prevent overheating. The microcontroller coordinates all system operations and ensures efficient energy management. Together, these components form an integrated system capable of converting road vibrations into usable electrical energy for EV charging.

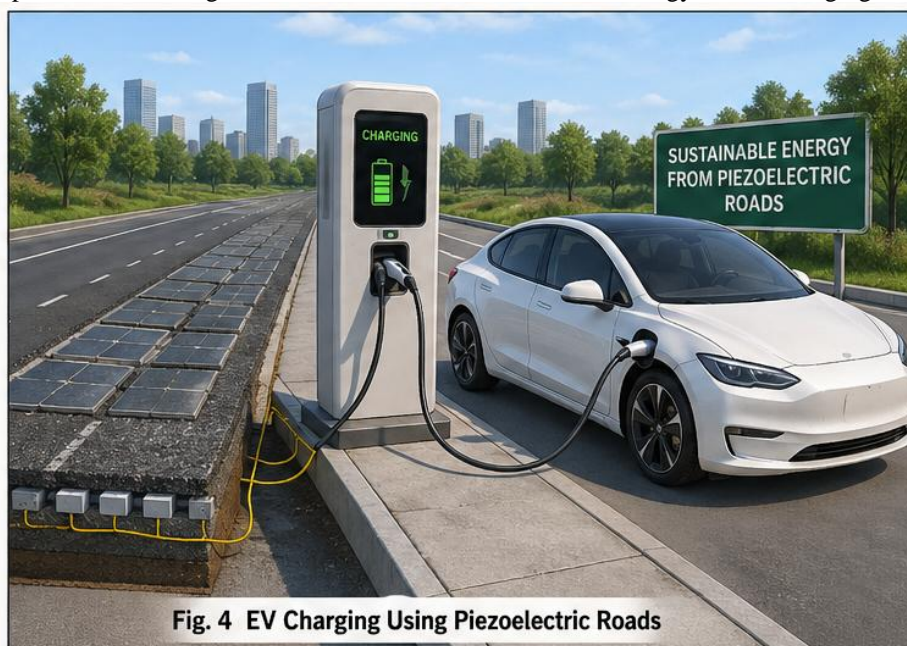

### 7. Software Implementation:

The system is programmed using the Arduino IDE, which provides a user-friendly platform for developing embedded applications. The software controls sensor data acquisition, energy management, and display operations. The microcontroller program continuously reads input from sensors and processes the data to control charging operations. It also updates the LCD display with real-time information. Simulation tools such as Proteus are used to test and validate the system before implementation. This ensures accuracy and reduces the risk of hardware failure.

### 8. Advantages:

The proposed system offers several advantages over conventional charging methods. It utilizes renewable mechanical energy, reducing dependence on the electrical grid. It supports eco-friendly transportation by lowering carbon emissions and promoting sustainable energy use. The system provides continuous energy generation as long as vehicles are in motion, making it more reliable than weather-dependent renewable sources. It also enhances infrastructure efficiency by transforming roads into energy-producing systems.

## 9. Conclusion:

The proposed system demonstrates a sustainable and innovative approach to EV charging by utilizing piezoelectric roads. It effectively captures mechanical energy from vehicle movement and converts it into electrical energy for charging applications. The integration of microcontroller-based control, energy storage, and monitoring systems ensures efficient and safe operation. This approach reduces dependency on conventional power grids and supports the development of smart city infrastructure. Although challenges such as installation cost and material durability remain, the system provides a promising solution for future transportation networks. By transforming roads into energy-generating assets, this technology contributes to cleaner, more efficient and sustainable mobility.

## References:

1. Y. Zhao and J. A. Abu Qahouq, "Second-Use Battery System for EV Charging Stations," *IEEE Transactions on Transportation Electrification*, vol. 9, no. 2, pp. 1450-1462, 2023.
2. K. L. Lim, S. Chung, and B. B. Park, "Assessment of Electric Vehicle Battery Fast Charging Characteristics," *Journal of Energy Storage*, vol. 72, pp. 108-120, 2025.
3. B. Malla and H. Myneni, "Analysis of Different Charging Methods of Batteries for EV Applications with Charge Equalization," *IEEE Access*, vol. 11, pp. 33450-33462, 2023.
4. S. Moussa and M. J. Ben Ghorbal, "Shepherd Battery Model Parametrization for Battery Emulation in EV Charging Application," *Energy Reports*, vol. 8, pp. 1223-1235, 2022.
5. R. R. Kumar, A. Singh, and P. Verma, "Advances in Batteries, Battery Management System, and Thermal Management in EV Applications," *Renewable and Sustainable Energy Reviews*, vol. 170, pp. 112-130, 2023.
6. D. K. Sharma, H. V. B. K, and V. R. Hulipalled, "EV Home Charging Infrastructure & Low Battery AI Algorithm," *International Journal of Smart Grid and Clean Energy*, vol. 11, no. 4, pp. 215-224, 2022.
7. Y. Zhang, X. Yang, B. Li, B. Cao, T. Li, and X. Zhao, "Two-Level Optimal Scheduling Strategy of Electric Vehicle Charging Aggregator Based on Charging Urgency," *IEEE Transactions on Smart Grid*, vol. 13, no. 5, pp. 3987-3998, 2022.
8. Y. Rohilla, P. Kundu, and D. Kumar, "Impact of Grid Disturbances on 2-Wheeler EV Battery Charging," *Electric Power Systems Research*, vol. 235, pp. 109-118, 2025.
9. M. E, B. V, G. Ezhilarasi, D. Lakshmi, S. R, and G. B, "IoT-Based Optimized Load Scheduling and Automation on Charging EV," *Journal of Internet of Things and Smart Systems*, vol. 5, no. 3, pp. 145-156, 2023.
10. M. T. Siddiqui, R. Gupta, A. P. Singh, and R. Gupta, "Constant Current-Constant Voltage Based EV Battery Charging Using High-Frequency Phase-Shift Full Bridge Converter," *IEEE Transactions on Power Electronics*, vol. 40, no. 1, pp. 567-578, 2025.